

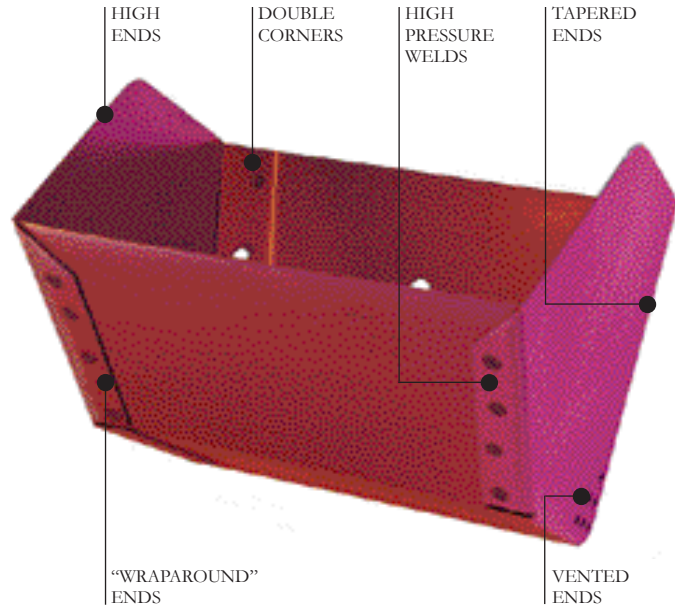

# ELEVATOR BUCKETS

## PROVEN PERFORMANCE

The merits and advantages of Sweetheart™ elevator buckets have been proven for over 50 years in thousands of bucket elevator installations. They have greater cubic inch capacities than plastic buckets of similar size. Vented ends provide faster and cleaner discharge including feeds and soft stock. Die-formed “wrap-around” ends that conform into matching offsets at the rear of the bucket provide reinforcement and a flat belt surface. Higher and tapered ends minimize spillage plus permit nesting for ease of handling, shipping, storage, and installation. Stainless steel and serrated digger buckets also available.



## SPECIFICATIONS

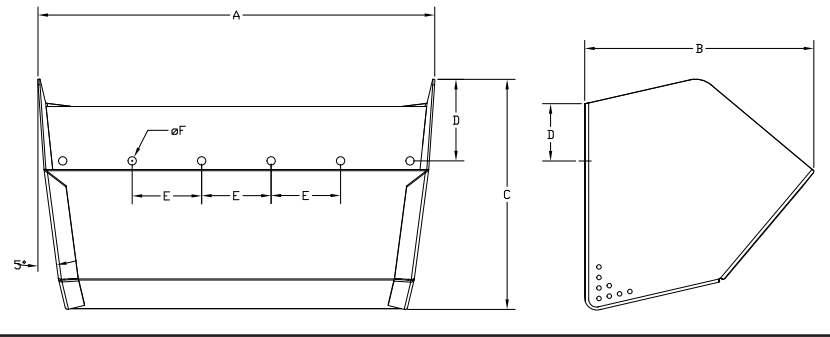

## DIMENSIONS

SIZE	LENGTH A	PROJECTION B	DEPTH C	TOP OF BACK TO CENTER OF BOLT HOLES D	CENTER TO CENTER OF BOLT HOLES E	DIA. OF BOLT HOLES F	DIA. OF BOLTS	NO. OF BOLT HOLES	BODY GAUGE STEEL	END GAUGE STEEL	GROSS CU. IN. CAPACITY 100% FULL	RECOMMENDED MINIMUM VERTICAL SPACING
6x4	6"	4.313"	3.375"	1.5"	4.375"	0.313"	0.25"	2	16	16	62	*SEE NOTE BELOW
6x5	6"	5.375"	4.75"	1.75"	4.375"	0.313"	0.25"	2	16	16	96	6"
9x5	9"	5.375"	4.75"	1.75"	3.625"	0.313"	0.25"	3	16	16	145	6"
9x6	9"	6.5"	5.75"	2"	3.625"	0.313"	0.25"	3	16	16	213	8"
10x6	10"	6.5"	5.75"	2"	4.125"	0.313"	0.25"	3	16	16	237	8"
12x6	12"	6.5"	5.75"	2"	3.375"	0.313"	0.25"	4	16	16	284	8"
15x6	15"	6.5"	5.75"	2"	3.25"	0.313"	0.25"	5	14	16	356	8"
12x7	12"	7.313"	6.625"	2"	3.375"	0.344"	0.313"	4	14	16	375	9"
15x7	15"	7.313"	6.625"	2"	3.25"	0.344"	0.313"	5	14	16	469	9"
10x9	10"	9.375"	8.5"	2.25"	4.125"	0.344"	0.313"	3	14	14	466	10"
13x9	13"	9.375"	8.5"	2.25"	3.75"	0.344"	0.313"	4	14	14	606	10"
14x9	14"	9.375"	8.5"	2.25"	3"	0.344"	0.313"	5	14	14	652	10"
16x9	16"	9.375"	8.5"	2.25"	2.875"	0.344"	0.313"	6	14	14	746	10"

\*NOTE: FOR 6X4 BUCKETS, RECOMMENDED VERTICAL SPACING IS 6" FOR ATOM ELEVATORS & 5" FOR BANTAM I ELEVATORS.  
NOTE: DIMENSIONS (IN INCHES) ARE FOR REFERENCE ONLY AND MAY BE SUBJECT TO CHANGE.



**OUR MISSION:** To provide innovative quality solutions that create an extraordinary customer experience.

# Sweetheart™ ELEVATOR BUCKETS

## BUCKET BOLT AND ASSOCIATED HARDWARE SELECTION

This specification is to be used for the selection of hardware to fasten buckets to the belt of bucket elevators.

The standard for steel buckets is to use a bucket bolt and hex nut with lock washer.

For plastic buckets, a flat washer should go on the inside of the bucket followed by a lock washer and hex nut. Do not use a washer between the bucket and the belt unless required by

the application, such as in seed applications, where the material may be entrapped behind the bucket. If a washer is required, it should be either a nylatron, neoprene, or leather washer.

For stainless steel bucket elevators, the same arrangement is to be used as above, but the hardware should be stainless steel. This includes the bucket bolts, nuts, flat washers, and lock washers.

### 1/4" Hardware

	220 PIW 2 PLY	330 PIW 3 PLY
--	------------------	------------------

#### 1/4" Hardware: steel buckets

Bucket bolt	1/4" x 1"	1/4" x 1-1/4"
Bolt with nut P/N	400385	400386
Split ring lock washer P/N	400496	400496

#### 1/4" Hardware - plastic buckets

Bucket bolt	1/4" x 1-1/4"	1/4" x 1-1/2"
Bolt with nut P/N	400386	400387
Flat washer P/N	400520	400520
Split ring lock washer P/N	400496	400496

#### 1/4" Hardware - steel buckets - with lap splice

Bucket bolt	1/4" x 1-1/4"	1/4" x 1-1/2"
Bolt with nut P/N	400386	400387
Split ring lock washer P/N	400496	400496

#### 1/4" Hardware - plastic buckets - with lap splice

Bucket bolt	1/4" x 1-1/2"	1/4" x 1-3/4"
Bolt with nut P/N	400387	455859
Flat washer P/N	400520	400520
Split ring lock washer P/N	400496	400496

### 5/16" Hardware

	330 PIW 3 PLY	440 PIW 4 PLY
--	------------------	------------------

#### 5/16" Hardware - steel buckets

Bucket bolt	5/16" x 1"	5/16" x 1-1/4"
Bolt with nut P/N	400390	400391
Split ring lock washer P/N	400497	400497

#### 5/16" Hardware - plastic buckets

Bucket bolt	5/16" x 1-1/4"	5/16" x 1-1/2"
Bolt with nut P/N	400391	400392
Flat washer P/N	400521	400521
Split ring lock washer P/N	400497	400497

#### 5/16" Hardware - steel buckets - with lap splice

Bucket bolts	5/16" x 1-1/4"	*See note below
Bolt with nut P/N	400391	
Split ring lock washer P/N	400497	

#### 5/16" Hardware - plastic buckets - with lap splice

Bucket bolt	5/16" x 1-3/4"	*See note below
Bolt with nut P/N	400393	
Flat washer P/N	400521	
Split ring lock washer P/N	400497	

\*NOTE: Sweet Manufacturing Company does not recommend lap splices on 440 PIW belt. AB heavy duty belt splice is standard on 440 PIW belt. Dura clamps (bar clamps) are available as an option for 220/330 PIW belts and will be quoted upon request.

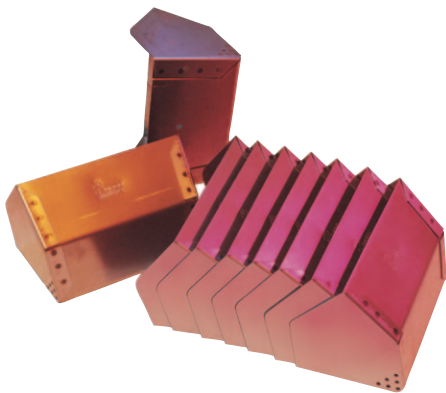

Telephone: 937-325-1511  
 Fax: 937-322-1963  
 Toll Free: 800-334-7254



Website: [www.sweetmfg.com](http://www.sweetmfg.com)  
 E-mail: [sales@sweetmfg.com](mailto:sales@sweetmfg.com)

P.O. Box 1086  
 Springfield, OH 45501